

X-RAY SYSTEM MAX70HFDC

Preinstallation – Documento di preinstallazione

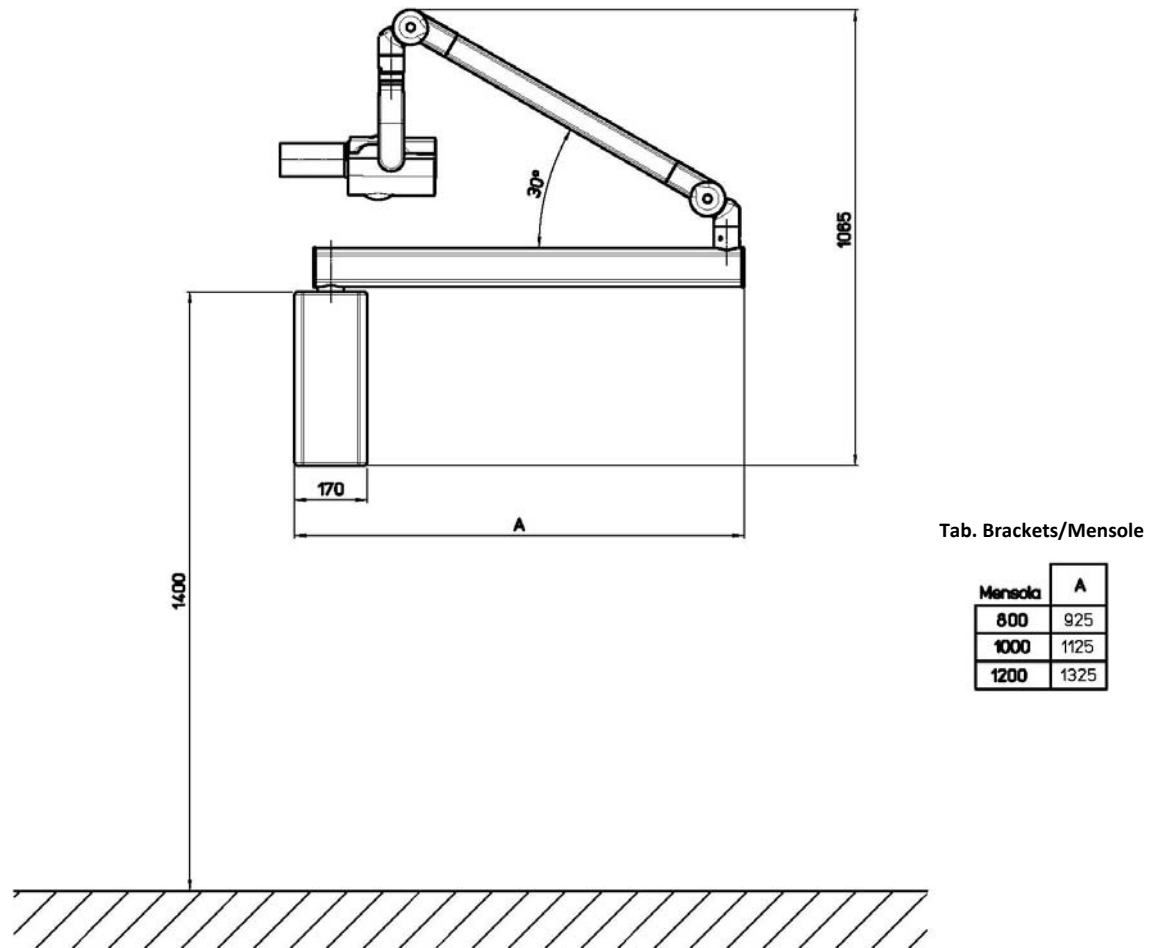
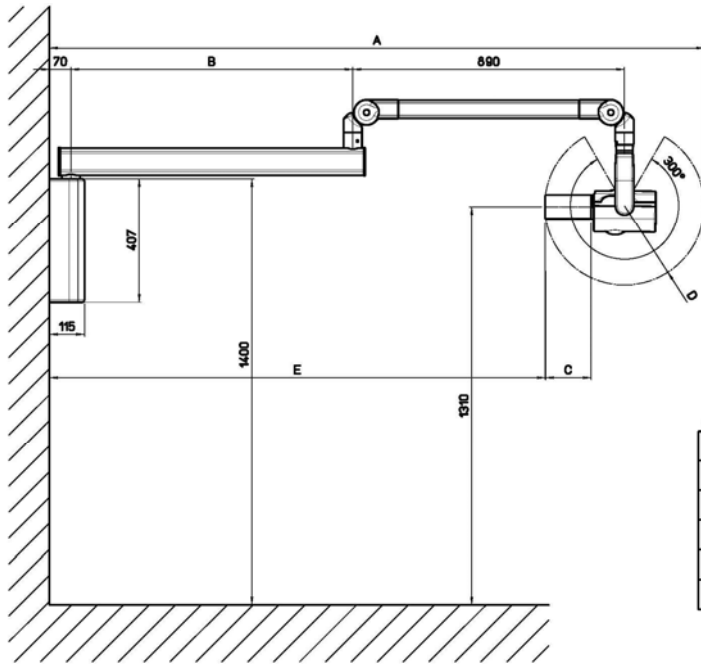

Fig. 1 – Closed arm at rest – For different brackets see table above.

Braccio ripiegato a parete – Le misure delle diverse mensole sono riportate in tabella.



Tab. Brackets/Mensole

MENSOLE / DPF	A	B	C	D	E
800 / 20	1933	800	63	173	1567
800 / 30	2033	800	163	273	1487
1000 / 20	2133	1000	63	173	1787
1000 / 30	2233	1000	163	273	1687
1200 / 20	2333	1200	63	173	1987
1200 / 30	2433	1200	163	273	1887

Fig. 2 – Maximum Reach (Extension) – For different brackets see table above.
 Estensione massima – Le misure delle diverse mensole sono riportate in tabella.

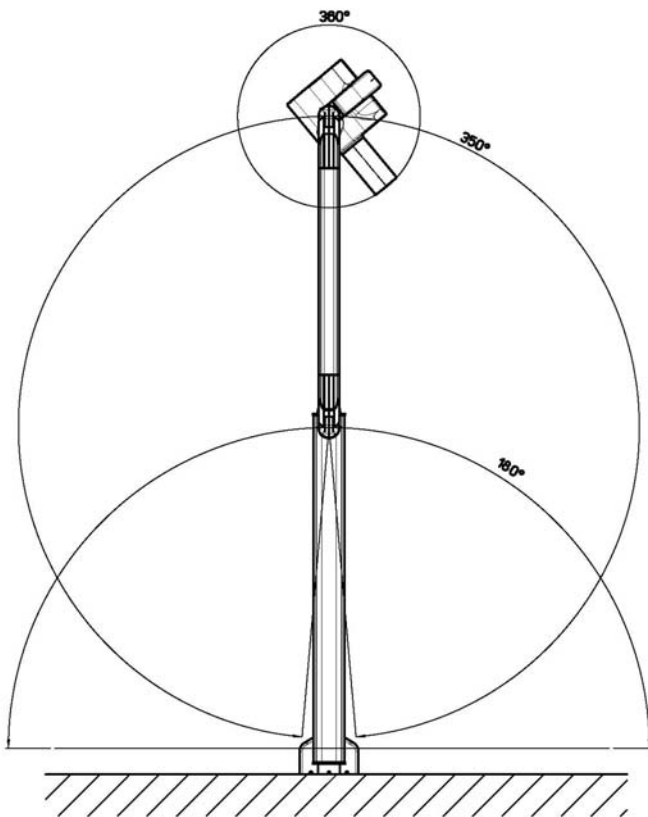
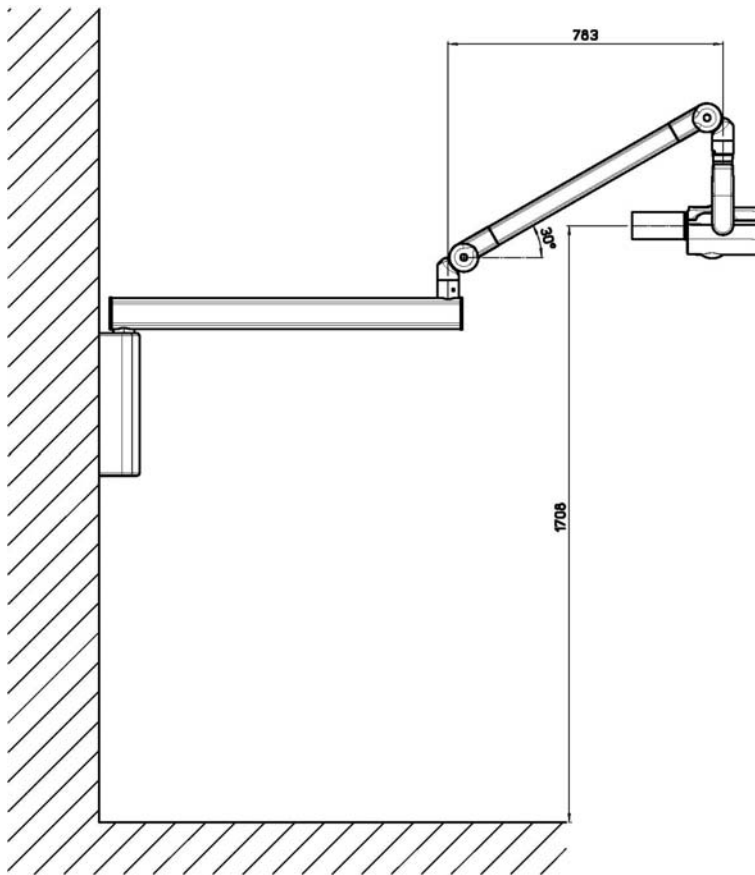
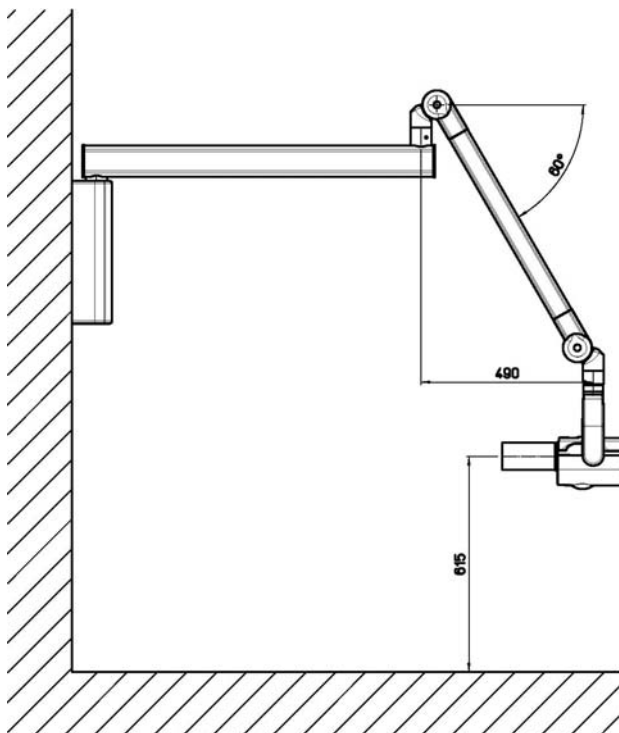

Fig. 3 – Maximum Reach (Extension) – Top view.
 Estensione massima – Vista dall'alto.

Dati soggetti a variazione senza preavviso – Data may be modified without notice.



*Fig. 4 – Extension at 30° up.
Estensione a 30° su.*



*Fig. 5 – Extension at 60° down.
Estensione a 60° giù.*

Dati soggetti a variazione senza preavviso – Data may be modified without notice.